

**MAGNEPLANAR® MG20.1**

Instruction Manual

White Bear Lake, Minnesota

[www.magnepan.com](http://www.magnepan.com)

## TABLE OF CONTENTS

1.	INTRODUCTION	Page 1
2.	GENERAL DESCRIPTION	Page 1
3.	ACCESSORY CARTON CONTENTS	Page 1
4.	IMPORTANT PRECAUTION	Page 1
5.	PACKAGING	Page 2
6.	ASSEMBLY	Page 2
7.	RIBBON TWEETER	Page 4
8.	FUSING	Page 5
9.	CABLE HOOKUP	Page 5
10.	SINGLE AMPLIFIER OPERATION	Page 5
11.	BI-AMPLIFICATION	Page 6
12.	SPEAKER PLACEMENT	Page 7
13.	ROOM ACOUSTICS	Page 8
14.	OPTIONAL TWEETER ATTENUATION	Page 9
15.	MAINTENANCE	Page 9
16.	SERVICE AND SHIPPING	Page 9
17.	TWEETER REPLACEMENT	Page 10
18.	MG20.1 SPECIFICATIONS	Page 11

## **1. INTRODUCTION**

Congratulations on your purchase. The Magneplanar® MG20.1 loudspeaker was conceived and designed for perfectionists. One of the most revealing loudspeakers made, the MG20.1 will provide outstanding music reproduction when used With high quality components.

## **2. GENERAL DESCRIPTION**

Your Magneplanar MG20.1 speaker system consists of a pair of mirror-imaged, Fabric and wood trimmed panels, labeled "1" and "2" (for identification). Each panel Contains one, five-foot long ribbon tweeter and one, mid/bass planar-magnetic driver. The Planar-magnetic driver consists of a quasi ribbon midrange section and a bass section, employing opposing magnet plates. The MG20.1's can be bi-amplified or bi-wired. The midrange to treble crossover components are housed in the speaker panel and are non- defeatable.

For single amplifier operation, a passive external crossover is supplied.

## **3. ACCESSORY CARTON CONTENTS**

- 4 - Speaker Support Feet
- 8 - Speaker Support Bolts
- 2 - 3 Amp Normal Blow Fuses (Tweeter)
- 2 - 5 Amp Normal Blow Fuses (Midrange)
- 4 - Wooden Handles
- 50 -Black Ribbon Tweeter Mounting Screws
- 2 - Speaker Emblems
- 1 - Allen Wrench
- 2 - 1 Ohm Resistors

## **4. IMPORTANT PRECAUTION**

The foil element in the ribbon tweeter is quite fragile. Handle them with extreme care when removing them from the carton. DO NOT remove the protective strip from the ribbon until the MG20.1 is fully assembled and the tweeters are installed.

**RUPTURED RIBBON ELEMENTS ARE NOT COVERED UNDER THE WARRANTY.**

## **5. PACKAGING**

Save all packaging, including ribbon tweeter packing! If you need to transport the speaker they can be shipped safely only in the original packaging. You may never have to ship or move your loudspeakers, but should the occasion arise, they should not be shipped in any packaging but the original. Should you discard it, factory packaging is available, including the special packaging for the ribbon tweeters.

## **6. ASSEMBLY**

You will note there are 4 wooden handles with threaded shafts. These are for attaching to the back side of the panels (2 each) to facilitate moving the speakers around. There are holes approximately 26 inches from the lower end of the panels for mounting these handles.

The four support feet for the MG20.1 speakers are shipped in the separate accessory carton along with the eight mounting bolts. Two feet must be fastened to the back side of each of the panels. The nuts are already installed in the panels.

- A.** Lay a speaker on its side as shown in Figure 1. We suggest you have a second person hold the speakers during installation to ensure they do not fall.

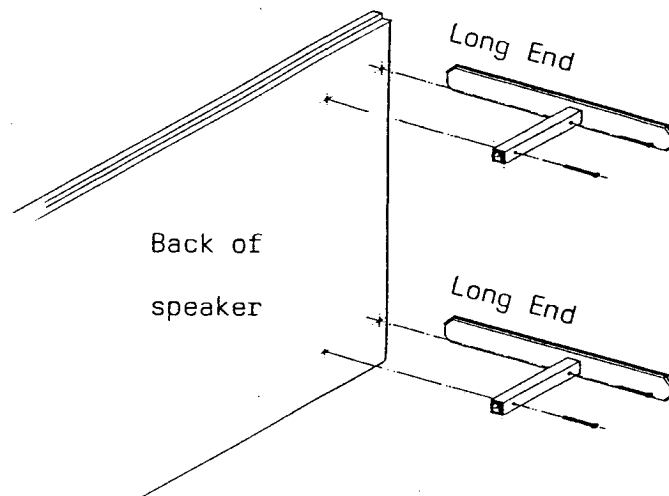

Figure 1

- B.** Locate the four holes in the fabric along back side of the panel.
- C.** Note that one section of the support feet is slightly longer than the other. Place the longer section toward the front of the speaker.
- D.** Align the holes in the foot with the holes in the panel. Using your fingers, insert the bolts through the foot and into the panel until they engage nuts in the panel. Care should be taken so the bolts do not cross-thread. Final tightening is done with a No. 2 Phillips screwdriver.
- E.** Repeat Steps C & D for the remaining feet.

There are threaded holes on the bottom of each speaker support which may be used to install spikes for installation on deep carpeting if desired.

## **7. RIBBON TWEETER**

The foil element in your MG20.1 line source tweeter is only .00015" thick, and is very fragile. Handle with extreme care. PLEASE READ FUSING ON PAGE 5. To lessen the risk of damage, the ribbon tweeters are shipped separately. Refer to the following instructions for installation.

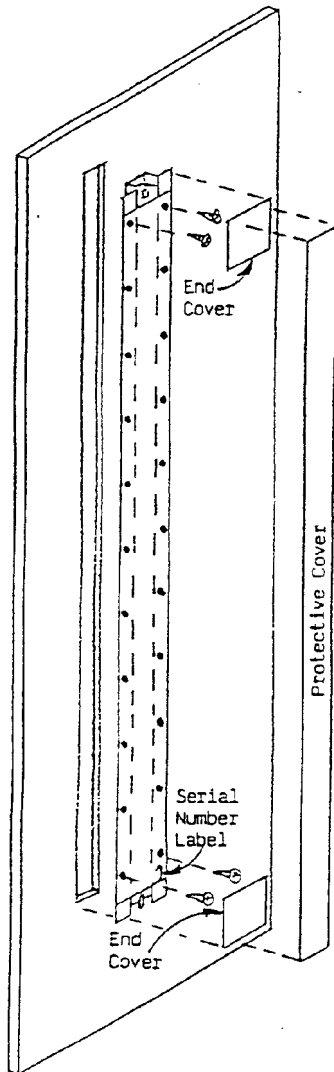

### **RIBBON TWEETER INSTALLATION / REMOVAL**

#### **INSTALLATION**

- A.** Mer the speaker has been stood upright, install the new ribbon tweeter in the frame. Serial number label must be at the bottom.
- B.** Insert the screws. Tighten until snug, then back off 1/2 revolution.
- C.** Remove protective cover and attach the wire to the ribbon terminals.
- D.** Peel liner from back of end covers and adhere to each end of tweeter.

#### **REMOVAL**

- A.** Pry away the two end covers.
- B.** Remove the wire at each end of the ribbon tweeter.
- C.** Remove the screws that attach the ribbon tweeter to the frame and then remove the tweeter.

**CAUTION:** Do not bump or touch the ribbon at end terminals.

**TOOLS NEEDED:** #2 Phillips Screwdriver

## **8. FUSING**

Your MG20.1's have been shipped with 3 amp fuses installed for the tweeter, and 5 amp fuses for the midrange. The fuses are Type 3AG normal blow fuses, and should never be replaced with slow blow fuses.

The maximum MIDRANGE fuse value shown on the speaker terminal plate is 5 amps. Under no circumstances should you exceed this value, or use slow blow fuses- doing so will invalidate your warranty.

"Clean" breaks of the ribbon foil are usually due to metal fatigue and may be covered under the terms of the warranty. Twisted, distorted or limp foil is usually caused by excessive power (from improper fusing), or sudden changes in air pressure and may not be covered under the terms of the warranty.

## **9. CABLE HOOKUP**

The MG20.1's feature high-current cable connectors which provide optimum contact area with speaker cables up to 10 gauge. To prepare cables, strip 1/2-inch of insulation from the end of the cable. Insert the bare wire into the connector and tighten the set-screw with the Allen wrench provided. Spade lug adapters are available from your Magneplanar dealer for speaker cables that are incompatible with the Magneplanar high-current connector.

## **10. SINGLE AMPLIFIER OPERATION**

For single amplifier operation an XO20.1 Passive Crossover has been supplied with your speakers.

- A.** Angle brackets have been provided for attaching the XO20.1 Crossover to the feet of the MG20.1's. This will ease moving and positioning the MG20.1's. Loosen top screws on back of feet, just enough to slip angle brackets on. Align the 4 gold connectors on the crossover to speaker inputs and place crossover on angle bracket. Tighten set screws.
- B.** Connect the amplifier speaker cables to the input of the XO20.1 Crossover box.
- C.** Every connection point on the XO20.1 Crossover is marked plus (+) or negative (-). Make a choice as to which lead is either positive or negative and make sure all connections are consistent with the marking.  
**DOUBLE-CHECK YOUR CONNECTIONS!** One mistake will put your system out of phase.

D. Bi-Wiring Option. Bi-wiring requires two sets of speaker cables. They may be identical, or one set may be specialized for high frequencies and the other specialized for low frequencies.

1. Remove both jumpers on the XO20.1 Crossover.
2. Connect one set of cables to the low cable input and the other set to the high cable input. Connect the other end of the cables together (observe +/- polarity), and connect to one channel of the amplifier outputs. If frequency specialized cables are used, connect them to their respective inputs. In either case the other ends are connected to the same amplifier channel.
3. Repeat same procedure for the other channel.

## 11. BI-AMPLIFICATION

The MG20.1 is conveniently arranged for hi-amplification. To hi-amplify, two stereo amplifiers (four channels of amplification) and an electronic crossover are required. For hi-amplifying with a conventional electronic crossover, connect the system as shown in Figure 2.

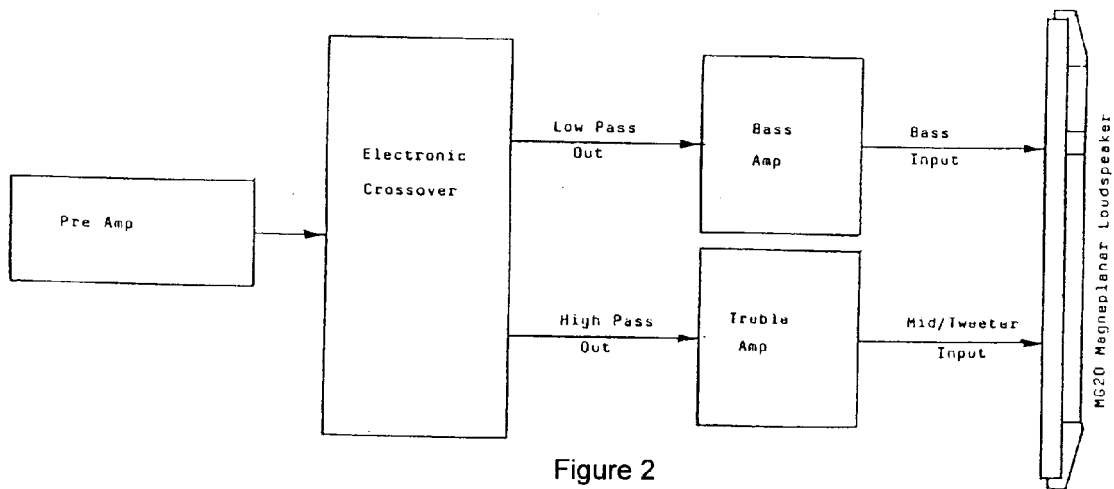

Set the high pass section at 200-300 Hz, 6dB per octave. Due to standing waves at the crossover frequency, the low pass section may require adjustment from as low as 90Hz (12dB Bessel) to 150Hz (15dB Butterworth). Typical settings are in the middle of this range. Optimization of the low pass can be done by ear (with music) or spectrum analysis.



With the crossover points set as listed above, the power requirements for the bass and mid/treble amps are nearly the same. Therefore, use amplifiers of similar power rating. It is suggested to use amplifiers rated at 100 watts RMS or greater, into 8 ohms.

Some amplifiers invert is phased correctly between phase and this test serves to double-check the entire system the bass and midrange.

## **12. SPEAKER PLACEMENT**

Proper speaker placement and room acoustics can have more effect on a music system than upgrading one of the components in the system. Unfortunately, there is no definitive guideline which will cover all possible listening rooms. Some experimentation is required for locating the optimum position. The following are a few general guidelines:

### TWEETER PLACEMENT

Room acoustics and your own personal tastes will determine whether to position the panels with the tweeters on the inside or outside edge. In most rooms placing them on the outside will give good dimensionality. Placing them on the inside will, in most cases, increase the central focus and improve imaging. For proper phasing between midrange and tweeter, the speakers should be toed in slightly. Align the foot below the tweeter with the listening position as shown in Figure 3.

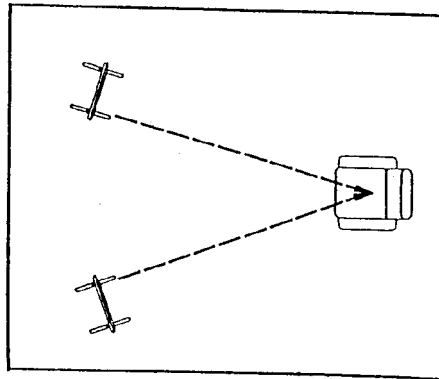

Figure 3

## **BASS RESPONSE**

If you do not have access to a spectrum analyzer, play a record with a repetitive bass line (preferably an acoustical bass instrument). Try the speakers in several parts of the room. Start experimenting with the speakers about 3 feet from the back wall. Try moving the speakers forward or backward by increments of 6 to 12 inches at a time. One part of the room should be noticeably better than the rest, as should one distance from the rear wall.

## **STEREO WIDTH AND IMAGING**

Once you have located the best position for the speakers and your chair for good bass performance, separate the tweeters by 50% of the distance from your chair to the speakers. (For example, if your chair is 10 feet from the speakers, move the tweeters 5 feet apart.) Now move the speakers apart in increments of 3 or 4 inches at a time, listening carefully at each position. At some point you will start to hear two separate speakers instead of getting a "stage effect" (or continuous image). If you have a hole-in-the-middle effect, your speakers are too far apart: begin moving the speakers closer together in small increments until you notice a point at which you achieve one cohesive "sound stage."

**NOTE:** Once you have located the ideal position you should mark it. A small tack or piece of tape can be placed on the carpet so your ideal listening spot can be easily relocated when the speakers (or chair) are moved for cleaning, etc. The entire placement procedure may seem like a great deal of work, but is necessary in the setup of any high quality system. The time and effort expended should be necessary only once, and will repay the owner with countless hours of musical enjoyment.

## **13. ROOM ACOUSTICS**

Magneplanars, like other bipolar speakers, usually sound best with a moderately reflective surface behind the speakers. In situations where the speakers must be placed closer than 2 feet from the back wall, a heavy damping material directly behind the speakers is advised; however, it should not cover the entire wall.

Damping material in other parts of the room is a matter of trial and error. A word of caution-when audiophiles discover the effectiveness of damping material, they sometimes overdo it (on the premise that if a little is good, more is better). Before you make a permanent change to your room, experiment with the positioning of the damping material. Usually a portion of one of two parallel walls should have some damping.

An over damped room will provide very precise imaging, but you will have a reduced sense of ambience (less reverberation, spaciousness). An under damped room may heighten the illusion of being in a concert hall, but the imaging will seem imprecise with all the instruments mixed together. Moderation is the word.

#### **14. OPTIONAL RIBBON TWEETER ATTENUATION**

There are two principal reasons for needing to attenuate the Magneplanar Ribbon Tweeter:

- A.** Recordings, typically in the "pop" or "rock" vein, often exhibit a pronounced rise in the treble region.
- B.** The Magneplanar Ribbon Tweeter is very efficient in its total "energy dispersion." If the surrounding walls are exceptionally reflective, the overall perceived acoustical balance will be tipped towards a "hot" high end.

Attenuation is performed through insertion of a simple non-inductive resistor in series with the tweeter.

There are inputs provided on the connector plate of each speaker for insertion of a resistor. To insert a resistor simply loosen the Allen screws, remove the jumper, insert the resistor, and tighten the screws. A 1 ohm non-inductive resistor will attenuate the tweeter approximately 2dB. Other values can also be used and are available from your Magneplanar dealer.

#### **15. MAINTENANCE**

The wood trim can be cleaned and polished with a damp cloth. In the event the speaker's fabric is damaged or soiled, replacement covers are available. **DO NOT VACUUM TWEETER CHANNEL!**

#### **16. SERVICE AND SHIPPING**

In the unlikely event you should need service for your MG20.1 loudspeakers, we recommend you return them through your dealer. He is experienced in providing service and can assist you if the speakers must be returned to the factory.

If it is determined that your speakers must be returned for repair, ship them (freight prepaid--ask for Rate Class 100 via truck) to: Magnepan, Incorporated, 1645 Ninth St., White Bear Lake, MN 55110. Include a packing slip or letter describing the nature of the problem. Please include your name, address, and a daytime telephone number.

Before packaging, very carefully install steel protector strips over the ribbon tweeters and remove the ribbon tweeters, following the removal instructions on Page 4. Do not let the steel strips slap against the magnets.

## **17. TWEETER REPLACEMENT**

Because the foil element in your MG20.1 line source tweeter is only .00015 inches thick, it is very fragile. Some users will never require a replacement tweeter. Failure will generally occur from mishandling, or from improper fusing. Users who frequently push the 3 amp tweeter fuse capacity will be the most likely to experience early failure. The tweeter has been designed to be easily replaced, requiring only a screwdriver. The time required should be less than 30 minutes.

If you have a defective tweeter, you should contact your dealer for a replacement. Your defective unit will be returned to Magnepan for installation of a new foil element at a minimal charge to you: there is no charge if it is within the one-year warranty period that covers the foil element and Magnepan determines that there is no evidence of abuse.

**DO NOT SHIP A TWEETER BACK TO MAGNEPAN WITHOUT CONTACTING YOUR DEALER OR MAGNEPAN FIRST.**

Tweeters must be returned in authorized containers only.

Tweeters that are damaged in shipment are the responsibility of the customer.

## **18. MG20.1 SPECIFICATIONS**

SYSTEM DESCRIPTION: 3-Way, Combination Diplanar® Bass/Diplanar Quasi

Ribbon Midrange and True Ribbon Tweeter

BASS SECTION: 786 Square Inches Planar-Magnetic

MIDRANGE SECTION: 137 Square Inches Quasi-Ribbon Planar Magnetic

TWEETER SECTION: 5/32 Inch Wide, 60 Inches Long

\*FREQUENCY RESPONSE-RIBBON DRIVER: +/- 3dB from \*\*25Hz to 40kHz

POLAR RESPONSE-RIBBON DRIVER: 180 Degrees Horizontal Dispersion Both Front and Back to 20kHz

RECOMMENDED MINIMUM POWER: 100 Watts RMS (8 Ohms rated)

RECOMMENDED MAXIMUM POWER: 300 Watts RMS (8 Ohms rated)

SENSITIVITY: 2.828v., 500Hz, 86dB @ 1 Meter

IMPEDANCE: 4 Ohms

CROSSOVER SYSTEM: Low-pass (bass): 18dB Butterworth @108Hz  
High-pass (midrange/tweeter): 6dB @330Hz

Crossover between midrange and tweeter is approximately 3000Hz and is non-defeatable.

DIMENSIONS: 29" x 79" x 2-1/2"

FINISH: Panels trimmed with natural oak, black oak, or dark cherry; covered With off-white, black or gray fabric

WARRANTY: Limited. Non-transferable-Ribbon foil element, 1 Year  
Balance of speaker - 3 Years

SHIPPING WEIGHT: 285 Lbs. with Accessory Packages

\*Because there are no universally accepted methods for loudspeaker measurement, frequency response specifications may be stated by most manufacturers without reference to measurement techniques and/or specific locations in rooms. Magneplanar loudspeaker frequency response curves are minimum average performance levels that may reasonably be expected in normal installations.

\*\*New Magneplanar MG20.1 speakers will not display their full bass potential. After a month or two of use the bass response will lower 5Hz or more. At this point the response will be realized. While this 5Hz or more of lower bass response is important, the most important factors in obtaining good bass response from the MG20.1 speakers are room size and geometry, wall material, and speaker placement.